

Operator's Manual

SLIT LAMP MICROSCOPE HS-5000 3X

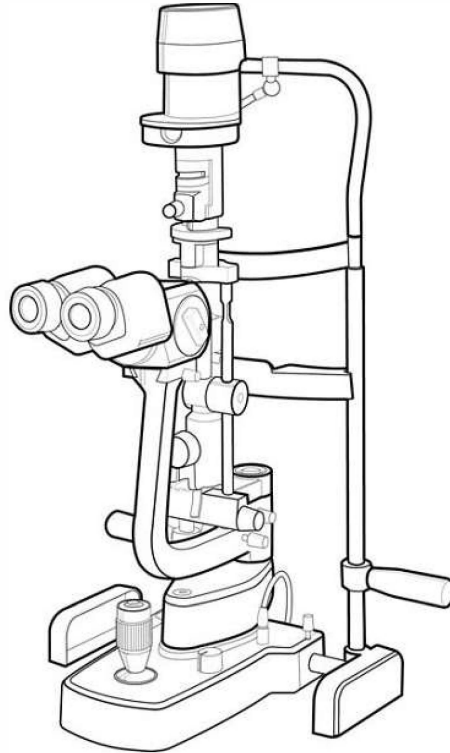

Huvitz
Paving Progress toward People

IMPORTANT NOTICE



Potential electromagnetic or other interference between medical equipments and other devices being operated together in the same environmental may exert an adverse influence on functioning of the medical equipment. Non-medical equipments not in compliance with the requirements of EN 60601-1 and EN 60601-1-2 should not be used together in the same environmental as the medical equipments

This equipment has been tested and found to comply with the limits for medical devices in IEC 60601-1-2:2001. These limits are designed to provide reasonable protection against harmful interference in a typical medical installation

Power Cord

For use of equipment in rated voltage less than 125Vac, minimum 6A, Type SJT or SVT , 18/3AWG, 10A, max 3.0m long : One end with Hospital Grade Type, NEMA 5-15P Other end with appliance coupler. For use of equipment in rated voltage less than 250Vac, minimum 6A, Type SJT or SVT , 18/3AWG, 10A, max 3.0m long : One end terminated with blade attachment plug(HAR) Type, NEMA 6-15P.

This product may malfunction due to electromagnetic waves caused by portable personal telephones, transceivers, radio-controlled toys, etc. Be sure to avoid having objects such as, which affect this product, brought near the product.

The information in this publication has been carefully checked and is believed to be entirely accurate at the time of publication. HUVITZ assumes no responsibility, however, for possible errors or omissions, or for any consequences resulting from the use of the information contained herein.

HUVITZ reserves the right to make changes in its products or product specifications at any time and without prior notice, and is not required to update this documentation to reflect such changes.

©2006 HUVITZ Co., Ltd.
689-3, Geumjeong-dong, Gunpo-si, Gyeonggi-do,
435-862, Republic of Korea

All rights are reserved.

Under copyright laws, this manual may not be copied, in whole or in part, without the prior written consent of HUVITZ Co., Ltd.

Document Number: 9000OMSL001-A, published in 2006/07/20

Contents

1. Introduction	6
1.1. Outline of the instrument.....	6
1.2. Classification.....	6
2. Safety Information.....	7
2.1. Introduction	7
2.2. Safety Symbols	8
2.3. Environment factors	10
2.4. Safety Precautions	12
3. Features & Operating Condition.....	14
3.1. Brief Description.....	14
3.2. Operating Condition	14
4. Standard Components.....	16
5. Accessories	17
6. Composition	18
7. Installation	23
7.1. Assembling the Instrument	23
8. Trial Operations.....	27
9. Main Features	28
10. Ordinary Maintenance	29

10.1.	Halogen Projection bulb	29
10.2.	Protection fuses replacement	31
10.3.	Cleaning & Disinfection	32
11.	EMC Information	33
11.1.	Guidance and manufacturer's declaration – electromagnetic emissions	33
11.2.	Guidance and manufacturer's declaration – electromagnetic immunity	34
11.3.	Guidance and manufacturer's declaration – electromagnetic immunity	36
11.4.	Recommended separation distances between portable and mobile RF communications equipment and the EUT	38
11.5.	Immunity and Compliance Level	39
11.6.	Guidance and manufacturer's declaration – electromagnetic immunity	40
12.	Electric Diagram	42
13.	Technical Specifications	43
14.	Service Information	45

1. Introduction

1.1. Outline of the instrument

The device works like all slit lamps:

- stereomicroscopic examination of the eye under the slit light.
- microscopic examination of the ocular fundus and posterior vitreous body (using hubry's lens).

These devices are designed for use by ophthalmologists and optometrists (within the realms of their respective professions) for specific diagnostic procedures (biomicroscopic examination of the eye)

1.2. Classification

Protection against electric shock: Class I

Applied Parts: Type B applied parts.

Protection against harmful ingress of water: Ordinary, IPX0

Degree of safety in the presence of a flammable anesthetics mixture with air or with oxygen or with nitrous oxide: Not suitable for use in the presence of a flammable anesthetics mixture with air or with oxygen or with nitrous oxide.

Mode of operation: Continuous

Stationary: Do not try to move this equipment without help. This microscope is heavy and should maintain stationary. Always get two persons to help lift this unit

2. Safety Information

2.1. Introduction

Safety is everyone's responsibility. The safe use of this equipment is largely dependent upon the installer, user, operator, and maintainer. It is imperative that personnel study and become familiar with this entire manual before attempting to install, use, clean, service or adjust this equipment and any associated accessories. It is paramount that the instructions contained in this manual are fully understood and followed to enhance safety to the patient and the user/operator. It is for this reason that the following safety notices have been placed appropriately within the text of this manual to highlight safety related information or information requiring special emphasis. All users, operators, and maintainers must be familiar with and pay particular attention to all Warnings and Cautions incorporated herein.

WARNING

“Warning” indicates the presence of a hazard that could result in severe personal injury, death or substantial property damage if ignored.

NOTE

“Note” describes information for the installation, operation, or maintenance of which is important but hazard related if ignored.

CAUTION





“Caution” indicates the presence of a hazard that could result in minor injury, or property damaged if ignored.



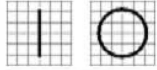

2.2. Safety Symbols

The International Electrotechnical Commission (IEC) has established a set of symbols for medical electronic equipment which classify a connection or warn of any potential hazards. The classifications and symbols are shown below.

This applies only to the instrument that has the certification symbol printed explicitly on the product label or sticker.







Save this instruction







	<p>I and O on power switch represent ON and OFF respectively.</p>
	<p>Type B Isolated patient connection.</p>
	<p>This symbol identifies a safety note. Ensure you understand the function of this control before using it. Control function is described in the appropriate User's or Service Manual.</p>
	<p>Identifies the point where the system safety ground is fastened to the chassis. Protective earth connected to conductive parts of Class I equipment for safety purposes.</p>
	<p>Hot surface.</p>

 <p>UL 60601-1 CAN/CSA C22.2 NO.601.1</p>	 <p>MEDICAL EQUIPMENT WITH RESPECT TO ELECTRIC SHOCK FIRE AND MECHANICAL HAZARDS ONLY IN ACCORDANCE WITH UL 60601- 1, AND CAN/CSA C22.2 NO.601.1</p>
	<p><u>Disposal of your old appliance</u> When this crossed-out wheeled bin symbol is attached to a product it means the product is covered by the European Directive 2002/96/EC. All electrical and electronic products should be disposed of separately from the municipal waste stream via designated collection facilities appointed by the government or the local authorities. The correct disposal of your old appliance will help prevent potential negative consequences for the environment and human health. 4. For more detailed information about disposal of your old appliance, please contact your city office, waste disposal service or the shop where you purchased the product.</p>
	<p>Alternating Current</p>

2.3. Environment factors

Avoid the following environments for operation or storage:

	<p>Where the equipment is exposed to water vapor. Don't operate an equipment with a wet hand.</p>
	<p>Where the equipment is exposed to direct sunlight.</p>
	<p>Where the temperature changes extremely. Normal operating temperature range is from 10°C to 40°C, Humidity is from 30% to 75%. Altitude is from 700 to 1060hpa</p>
	<p>Where it is near the heat equipment.</p>
	<p>Where the humidity is extremely high or there is a ventilation problem.</p>
	<p>Where the equipment is subject to excessive shocks or vibrations.</p>

	<p>Where equipment is exposed to chemical material or explosive gas.</p>
	<p>Be careful not to be inserted dust, especially, metal.</p>
	<p>Don't disassemble the product or open. We aren't responsible for it for nothing.</p>
	<p>Be careful not to close the fan located on the lateral or back side of the equipment.</p>
	<p>Don't plug the AC power cord into the outlet before the connection between devices of the equipment is completed. This can generate the defect.</p>
	<p>Pull out the power cord with holding the plug, not the cord.</p>

Avoid places where the ambient temperature falls below 10°C or exceeds 40°C for normal operation, or below -10°C or exceeds 40°C (14°F-104°F) for transportation and storage. Humidity should be maintained between 30 and 75% for normal operation, transportation and storage. The atmospheric pressure in operation, transportation and storage is from 700 to 1060hpa.

2.4. Safety Precautions

This equipment has been developed and tested according to safety standards as well as national and international standards. This guarantees a very high degree of safety for this device. The legislator expects us to inform the user expressively about the safety aspects in dealing with the device. The correct handling of this equipment is imperative for its safe operation. Therefore, please read carefully all instructions before switching on this device. For more detailed information, please contact our Customer Service Department or one of our authorized representatives.

1. This equipment must not be used (a) in an area that is in danger of explosions and (b) in the presence of flammable, explosive, or volatile solvent such as alcohol, benzene or similar chemicals.
2. Do not put or use this device in humid rooms. Humidity should be maintained between 30 and 75% for normal operation. Do not expose the device to water splashes, dripping water, or sprayed water. Do not place containers containing fluids, liquids, or gases on top of any electrical equipment or devices.
3. The equipment must be operated only by, or under direct supervision of a properly trained and qualified person.
4. Modifications of this equipment may only be carried out by Huvitz's service technicians or other authorized persons.
5. Customer maintenance of this equipment may only be performed as stated in the User's Manual and Service Manual. Any additional maintenance may only be performed by Huvitz's service technicians or other authorized persons.
6. The manufacturer is only responsible for effects on safety, reliability, and performance of this equipment when the following requirements are fulfilled: (1) The electrical installation in the respective room corresponds to the specifications stated in this manual and (2) This equipment is used, operated,

and maintained according to this manual and Service Manual.

7. The manufacturer is not liable for damage caused by unauthorized tampering with the device(s). Such tampering will forfeit any rights to claim under warranty.
8. This equipment may only be used together with accessories supplied by Huvitz's. If the customer makes use of other accessories, use them only if their safe usability under technical safety aspects has been proved and confirmed by Huvitz or the manufacturer of the accessory.
9. Only persons who have undergone proper training and instructions are authorized to install, use, operate, and maintain this equipment.
10. Keep the User's Manual and Service Manual in a place easily accessible at all times for persons operating and maintaining the equipment.
11. Do not force cable connections. If a cable does not connect easily, be sure that the connector (plug) is appropriate for the receptacle (socket). If you cause any damage to a cable connector(s) or receptacle(s), let the damage(s) be repaired by an authorized service technician.
12. Please do not pull on any cable. Always hold on to the plug when disconnecting cables.
13. Before every operation, visually check the equipment for exterior mechanical damage(s) and for proper function.
14. Do not cover any ventilation grids or slits.
15. Immediately turn off and unplug any equipment that gives off smoke, sparks, strange noises, or odors.
16. Power Supply Cord set (international) - (Detachable) Rated 10 A, 250 V. Plug type CEE 7/VII, Connector type IEC 60320/C13, and Cord type H05VV-F3G, min. 0.75 mm², 3-conductor terminating in molded-on grounding type attachment plug. <HAR> marked on the cord. Maximum 4.0 m long.

3. Features & Operating Condition

3.1. Brief Description

The device works like all slit lamps:

- stereomicroscopic examination of the eye under the slit light.
- microscopic examination of the ocular fundus and posterior vitreous body (using hubry's lens).

These devices are designed for use by ophthalmologists and optometrists (within the realms of their respective professions) for specific diagnostic procedures (bio-microscopic examination of the eye)

3.2. Operating Condition

- As long as the slit lamp is in its original package it can be exposed to the following environmental conditions for up to 15 weeks for shipping and storage without risk of damage:
 - Temperature range : from -10°C to $+40^{\circ}\text{C}$;
 - Relative humidity range: from 30% to 75%;
- The device is made to operate under the following environmental conditions:
 - Temperature range : from $+10^{\circ}\text{C}$ to $+40^{\circ}\text{C}$;
 - Relative humidity range: from 30% to 75%;

The device neither generates nor receives electromagnetic interference when used near other equipment. Therefore, no preventive or corrective measures are required

 **CAUTION**

Because prolonged intense light exposure can damage the retina, the use of the device for ocular examination should not be unnecessarily prolonged, and the brightness setting should not exceed what is needed to provide clear visualization of the target structures. This device should be used with filters that eliminate UV radiation (<400nm) and, whenever possible, filters that eliminate short-wavelength blue light (<420nm).

The retinal exposure dose for a photochemical hazard is a product of the radiance and the exposure time. If the value of radiance were reduced in half, twice the time would be needed to reach the maximum exposure limit.

While no acute optical radiation hazards have been identified for slit lamps, it is recommended that the intensity of light directed into the patient's eye be limited to the minimum level which is necessary for diagnosis. Infants, aphakes and persons with diseased eyes will be at greater risk. The risk may also be increased if the person being examined has had any exposure with the same instrument or any other ophthalmic instrument using a visible light source during the previous 24 hours. This will apply particularly if the eye has been exposed to retinal photography.

4. Standard Components

The instrument is delivered in package. Taking it out of the package, make sure that none of the following parts is missing.

- A table top(N.B. the table top isn't supplied with the slit lamp for twin table) on which are placed: A SMPS box(15) including the main switch & a warning light (13), Two sliding guides for the base with orthogonal movements(17), A sliding plate for the position device(19), A drawer(16);
- A base with orthogonal movements.
- A microscope with either dual magnification or a system(31) including eyepieces.
- An optical group of the slit projector.
- A head rest module(59).
- A microscope arm(45).
- This manual.
- A set of accessories including; two wheels for the sliding guides(18); a setting rod(43); a protective cover(46); a spare bulb 12V 30W Halogen bulb(53); two protection fuses(48); a breath screen(19); a chin-rest paper(47);a hole cover(45); a power cable; two patient's handles(50)

5. Accessories

The following standard accessories are provided with the instrument;

- protection cover(46)
- a setting rod(43)
- spare bulbs
12V 30W Halogen bulb(53)
- chin-rest paper(47)
- spare fuses
250Vac T2.0AL
- a breath screen(5)
- power cable

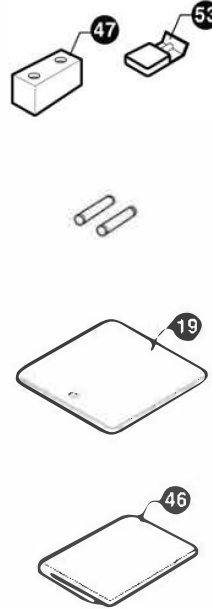

[Figure 1. Accessories]

6. Composition

- 1) Fixation point
- 2) Control lever for changing enlargement
- 3) Removable eye-pieces
- 4) Knob for clamping the breath screen
- 5) Breath screen
- 6) Control handle for the slit rotation 90-0-90
- 7) Connecting plug of the projector lamp
- 8) Knurled ring for filters insertion
- 9) Joystick for lateral, longitudinal and vertical movements(x y z)
- 10) Base with orthogonal movements
- 11) Shaped tabletop
- 12) Warning light indicating the ignition of the SMPS is on
- 13) Main switch & Warning light
- 14) Luminosity selector
- 15) SMPS box
- 16) Drawer
- 17) Toothed guides
- 18) Wheel protection crankcases
- 19) Sliding plate
- 20) Knob to lock the projector
- 21) Scale for the projector position
- 22) Knob to lock the arm of the microscope
- 23) Hole cover
- 24) Knurled knob to lift the bulb holder
- 25) Ring for the vertical setting of the chin-rest

- 26) Locking pins for chin rest paper
- 27) Chin rest
- 28) Knobs to change the slit width
- 29) Pointer for the eye positioning
- 30) Head rest
- 31) Microscope
- 32) Bulb feeding contacts
- 33) Knob to lock the base of the instrument
- 34) Knob to lock the microscope
- 35) Control handle for horizontal tilting
- 36) Control lever for vertical tilting
- 37) Microscope position stop
- 38) Graduated ring 90-0-90 determining the inclination of the slit during rotation
- 39) Lamp cover
- 40) fuse slots
- 41) Connecting plug
- 42) Fixation point connector
- 43) Setting rod
- 44) Microscope separation knob
- 45) Microscope arm
- 46) Protection cover
- 47) Chin rest papers
- 48) Guide screw
- 49) An optical group of the slit projector
- 50) Patient's handle
- 51) Chin rest fastening screw
- 52) Wheel
- 53) Halogen bulb 12V 30W

20 SLIT LAMP HS-5000 3X-----

- 54) Bulb fastening knob
- 55) Mirror
- 56) Capture connector (For the image system)
- 57) Capture switch
- 58) Luminosity selector connector (Connect the Luminosity selector to the SMPS)
- 59) Head rest module

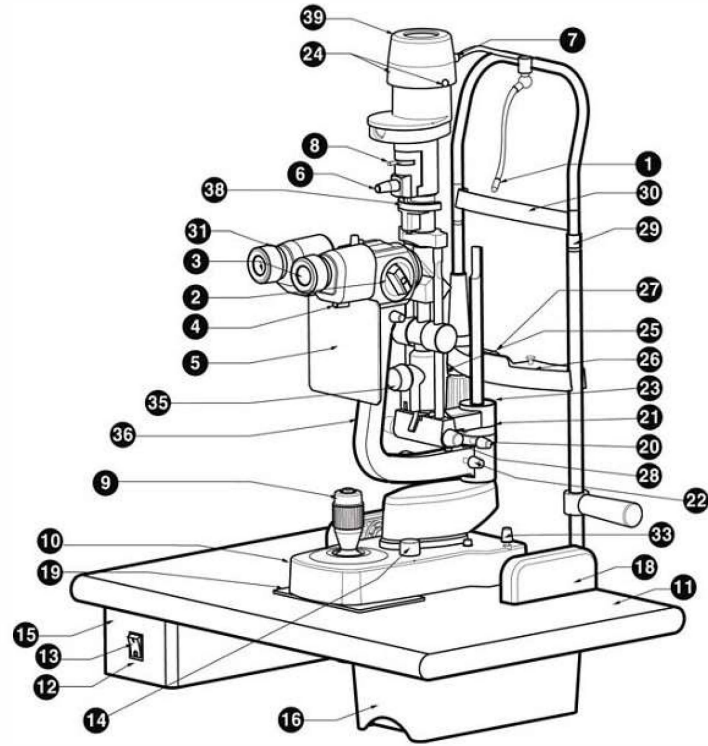

[Figure 2. Composition I]

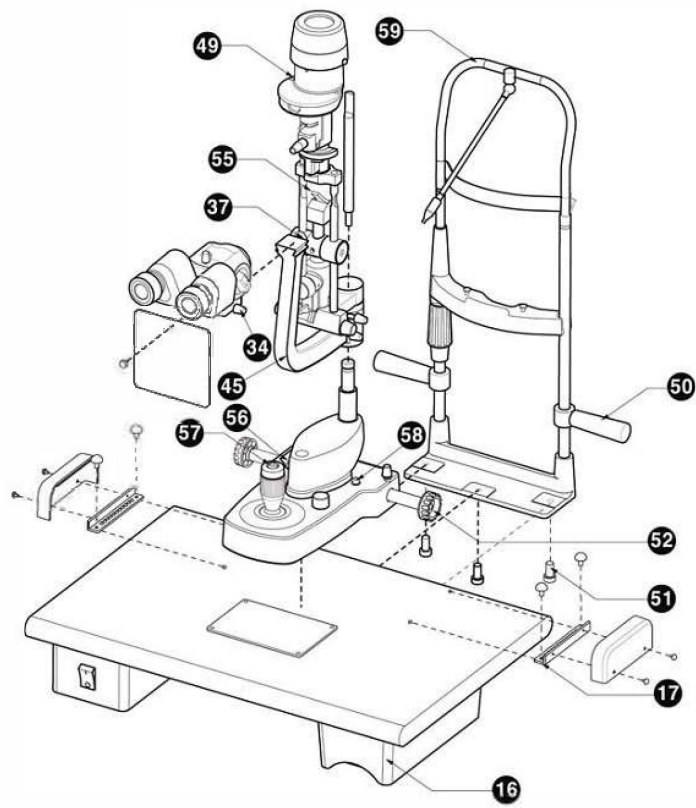

[Figure 3. Composition II]

7. Installation

NOTE

The appliances are always supplied with excellent packaging to be able to stand up to all kinds of transport and standard storage conditions. Please contact the suppliers if any irregularities are found in the appliance due to transport after unpacking

7.1. Assembling the Instrument

- Put the table top on a very stable support. Block the two parts together by tightening the screws

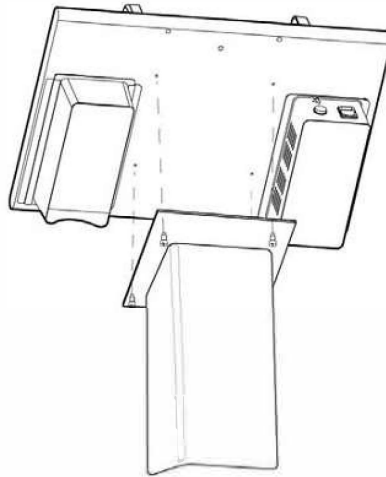

[Figure 4. Table Assembling]

- Place the head rest module(59) and make sure that its holes fit together with those of the table top. Tighten the screw with the screw driver

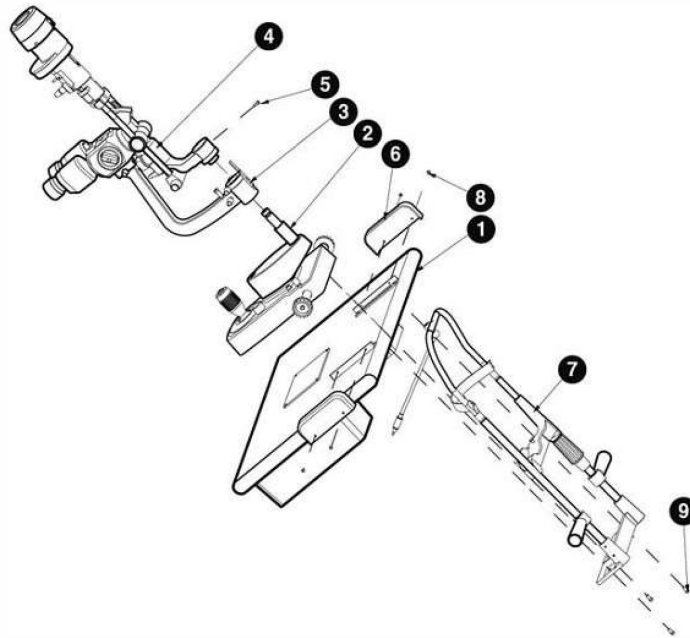

[Figure 5. Assembling the instrument I]

- Place the base with orthogonal movements on the guides situated on the upper part of the table top, checking that the wheels are in line. Then Place the crankcase(59) and make sure that its holes fit together with those of the toothed guides(17). Tighten the screw with the screw driver(+)
- Assemble the microscope arm(45) on the Base with orthogonal movements(10).

- Assemble An optical group of the slit projector(49) on the Base with orthogonal movements(10). Then tighten the Guide screw with the screw driver(-)
- Put the microscope(31) in the right position making sure that it is placed well in the stop(37); then tighten it with the knob(34)situated the right side of the microscope.
- Fasten the breath screen(5) with the knob(4)
- Insert the connecting cable into the socket.

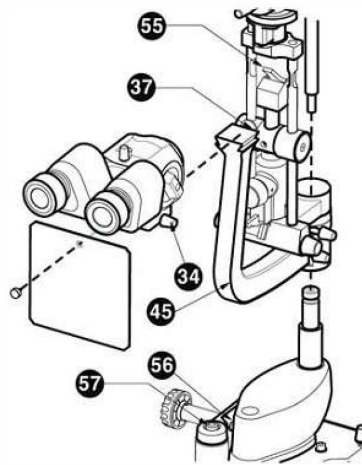



[Figure 6. Assembling the instrument II]

8. Trial Operations

- Assemble the chin-rest paper(47) on the chin-rest(27).
- Let the patient sit down comfortable with his chin on the chin-rest and his forehead against the forehead-rest.
- Lift or lower the chin-rest by moving the handle (25) so that the patient's eyes are in line with the notches on the chin-rest(29)
- Switch the instruments on, press the switch(13). You will see the warning light on (12).
- Adjust the luminous intensity by moving the selector(14)
- Frame and focus the eye to be examined by moving the lever(9)

9. Main Features

Principal operative characteristics of the instrument:

- Observation without settling or tiring and rapid change of enlargements.
- Base with cross-wise movement (which can be stopped) commanded by a single joystick for all adjustments(x y z)
- Stereomicroscopical observation of the eye with enlargements 10X-16X-25X (3 enlargements model).
- Tilting 5°-10°-15°-20°
- Microscopy of the back part and of the posterior vitreous body by means of the Hruby lens or a contact options.(Goldman lens).
- Observation of the eye and valuation of the position of contact lenses in a fluorescent light.
- Tonometry with Goldman tonometer.
- Measurement of the cornea diameter and contact lenses.
- Shooting and video recording of the eye
- Survey which reveals the axis of the contact lens, thanks to the possible reading of the rotation angle of the slit which includes all the meridians.

10. Ordinary Maintenance

WARNING

The repairs illustrated below should all be carried out with the power cable disconnected from the main supply plug. Please contact the suppliers for any other problems that cannot be resolved by the operations described below.

CAUTION

Please turn off the power switch before replacing lamps. Please place lamps after cooling down. The heated lamp may burn your fingers.

NOTE

Don't touch any other parts of glass tube with the bare fingers. Fingerprints, if any, must be wiped off from the glass tube with alcohol

10.1. Halogen Projection bulb

To replace the Halogen projection bulb proceed as follow.

- Before doing anything else, disconnect the plug from the main supply socket;
- Remove the screws with the driver(24), Remove the cover(39),
- Remove the connectors(32) from the bulb stems;
- Rotate the knob(54) to loosen the bulb stop
- Remove the burnt out bulb; be careful , it could be very hot;
- Replace it with a new one(12V30W Halogen) using the plastic envelope(never

30 SLIT LAMP HS-5000 3X-----

touch the bulb with fingers)

- Fasten the bulb with the knob
- Make sure that the stems of the bulb are completely inserted; insert the plug in the main supply socket

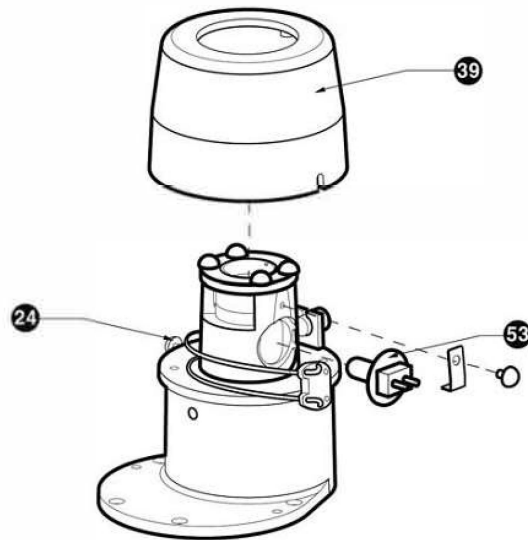

[Figure 7. Replace Halogen bulb]

 **WARNING**

Don't Touch to the Lamp House, During the Operation.
It's Heating up.

10.2. Protection fuses replacement

To replace the fuses proceed as follows:

- The protection fuses are placed on the back of the SMPS, and inserted power socket. Before doing anything else, disconnect the plug from the main supply socket
- Remove the burned-out fuses
- Substitute the fuses and check
- Replace the plug in the main supply socket.

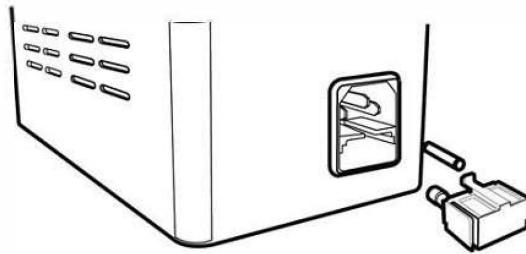

[Figure 8. Replace the fuse]



Replace fuses with the same rating and type(250Vac, T2.0AL)

10.3. Cleaning & Disinfection

- To keep the device clean, apply clinical alcohol and cidex or cidex plus on a soft cloth and scrub the body and the probe once a month. Do not use lacquer, thinner, ethylene, or the oxidizing substance.
- If the instrument is not in use, dust must be kept away by covering the instrument with the supplied plastic cover. Dust accumulating during the functioning of the instrument must be periodically removed with a very soft cloth or with a small pump.

11. EMC Information

11.1. Guidance and manufacturer's declaration – electromagnetic emissions

<p>The EUT is intended for use in the electromagnetic environment specified below. The customer or the user of the EUT should assure that it is used in such an environment.</p>		
Immunity test	Compliance	Electromagnetic environment - guidance
RF Emissions CISPR 11	Group 1	The EUT uses RF energy only for its internal function. Therefore, its RF emissions are very low and are not likely to cause any interference in nearby electronic equipment
RF Emissions CISPR 11	Class B	The EUT is suitable for use in all establishments, including domestic establishments and those directly connected to the public low-voltage power supply network that supplies buildings used for domestic purposes
Harmonic emissions IEC 61000-3-2	Class A	
Voltage fluctuations/ Flicker emissions IEC 61000-3-3	Complies	

11.2. Guidance and manufacturer's declaration – electromagnetic

immunity

The EUT is intended for use in the electromagnetic environment specified below. The customer or the user of the EUT should assure that it is used in such an environment.			
Immunity test	IEC 60601 Test level	Compliance level	Electromagnetic environment -guidance
Electrostatic discharge (ESD) IEC 61000-4-2	±6kV Contact ±8kV air	±6kV Contact ±8kV air	Floors should be wood, concrete or ceramic tile. If floors are covered with synthetic material, the relative humidity should be at least 30%.
Electrical fast transient/burst IEC 61000-4-4	±2kV for power supply lines ± 1kV for input/output lines	±2kV for power supply lines ± 1kV for input/output lines	Mains power quality should be that of a typical commercial or hospital environment.
Surge IEC 61000-4-5	±1kV differential mode ±2kV common mode	±1kV differential mode ±2kV common mode	Mains power quality should be that of a typical commercial or hospital environment.
Voltage dips, short interruptions and voltage variations on power supply input lines IEC 61000-4-11	<5% U _T (>95% dip in U _T) for 0.5cycle 40% U _T (60% dip in U _T) for 5 cycle 70% U _T (30% dip in U _T) for 25 cycle	<5% U _T (>95% dip in U _T) for 0.5cycle 40% U _T (60% dip in U _T) for 5 cycle 70% U _T (30% dip in U _T) for 25 cycle <5% U _T (<95% dip in	Mains power quality should be that of a typical commercial or hospital environment. If the user of the EUT image intensifier require continued operation during power mains interruptions, it is recommended that the

	<5% U_T (<95% dip in U_T) for 5 s	U_T) for 5 s	EUT image intensifier be powered from an uninterruptible power supply or a battery.
Power frequency (50/60Hz) magnetic field IEC 61000-4-8	3 A/m	3 A/m	Power frequency magnetic fields should be at levels character istic of a typical location in a typical commercial or hospital environment.
NOTE U_T is the a.c. mains voltage prior to application of the test level.			

11.3. Guidance and manufacturer's declaration – electromagnetic immunity

The EUT is intended for use in the electromagnetic environment specified below. The customer or the user of the EUT should assure that it is used in such an environment.

Immunity test	IEC 60601 test level	Compliance level	Electromagnetic environment - guidance
Conducted RF IEC 61000-4-6	3 Vrms 150 kHz to 80MHz	3 Vrms 150 kHz to 80MHz	Portable and mobile RF communications equipment should be used no closer to any part of the EUT, including cables, than the recommended separation distance calculated from the equation applicable to the frequency of the transmitter. Recommended separation distance $d = \left[\frac{3,5}{V_1} \right] \sqrt{P}$ $d = \left[\frac{3,5}{E_1} \right] \sqrt{P} \quad 80 \text{ MHz to } 800 \text{ MHz}$ $d = \left[\frac{7}{E_1} \right] \sqrt{P} \quad 800 \text{ MHz to } 2,5 \text{ GHz}$ where P is the maximum output power rating of the transmitter in watts (W) according to the transmitter manufacturer
Radiated RF IEC 61000-4-3	3 V/m 80 MHz to 2.5GHz	3 V/m 80MHz to 2.5GHz	

			<p>and d is the recommended separation distance in meters (m).</p> <p>Field strengths from fixed RF transmitters, as determined by an electromagnetic site survey,^a should be less than the compliance level in each frequency range.^b</p> <p>Interference may occur in the vicinity of equipment marked with the following symbol :</p> 
--	--	--	--

<p>NOTE 1) At 80MHz and 800MHz, the higher frequency range applies.</p> <p>NOTE 2) These guidelines may not apply in all situations. Electromagnetic propagation is affected by absorption and reflection from structures, objects and people.</p> <p>^a Field strengths from fixed transmitters, such as base stations for radio (cellular/cordless) telephones and land mobile radios, amateur radio, AM and FM radio broadcast and TV broadcast cannot be predicted theoretically with accuracy. To assess the electromagnetic environment due to fixed RF transmitters, an electromagnetic site survey should be considered. If the measured field strength in the location in which the EUT is used exceeds the applicable RF compliance level above, the EUT should be observed to verify normal operation. If abnormal performance is observed, additional measures may be necessary, such as re-orienting or relocating the EUT.</p> <p>^b Over the frequency range 150kHz to 80MHz, field strengths should be less than [V_r] V/m.</p>

11.4. Recommended separation distances between portable and mobile RF communications equipment and the EUT

This is intended for use in an electromagnetic environment in which radiated RF disturbances are controlled. The customer or the user of the EUT can help prevent electromagnetic interference by maintaining a minimum distance between portable and mobile RF communications equipment (transmitters) and the EUT as recommended below, according to the maximum output power of the communications equipment.

Rated maximum output power of transmitter [W]	Separation distance according to frequency of transmitter [m]		
	150kHz to 80MHz $d = \left[\frac{3,5}{V_1} \right] \sqrt{P}$ $V_1 = 3V_{rms}$	80MHz to 800MHz $d = \left[\frac{3,5}{E_1} \right] \sqrt{P}$ $E_1 = 3V/m$	800MHz to 2.5GHz $d = \left[\frac{7}{E_1} \right] \sqrt{P}$ $E_1 = 3V/m$
0.01	0.116	0.1166	0.2333
0.1	0.368	0.3687	0.7378
1	1.166	1.1660	2.3333
10	3.687	3.6872	7.3785
100	11.660	11.6600	23.333

For transmitters rated at a maximum output power not listed above, the recommended separation distance d in metres (m) can be estimated using the equation applicable to the frequency of the transmitter, where p is the maximum output power rating of the transmitter in watts (W) according to the transmitter manufacturer.

NOTE 1) At 80MHz and 800MHz, the separation distance for the higher frequency range applies.

NOTE 2) These guidelines may not apply in all situations. Electromagnetic propagation is affected by absorption and reflection from structures, objects and people.

11.5. Immunity and Compliance Level

Immunity test	IEC 60601 Test Level	Actual Immunity Level	Compliance Level
Conducted RF IEC 61000-4-6	3Vrms 150kHz to 80MHz	3Vrms	3Vrms
Radiated RF IEC 61000-4-3	3Vrms 80MHz to 2.5GHz	3V/m	3V/m

11.6. Guidance and manufacturer's declaration – electromagnetic immunity

The EUT is intended for use in the electromagnetic environment specified below.
 The customer or the user of the EUT should assure that it is used in such an electromagnetic environment.

Immunity test	IEC 60601 test level	Compliance level	Electromagnetic environment - guidance
Conducted RF IEC 61000-4-6	3 Vrms 150 kHz to 80MHz	3 Vrms 150 kHz to 80MHz	The EUT must be used only in a shielded location with a minimum RF shielding effectiveness and, for each cable that enters the shielded location with a minimum RF shielding effectiveness and, for each cable that enters the shielded location
Radiated RF IEC 61000-4-3	3 V/m 80 MHz to 2.5GHz	3 V/m 80MHz to 2.5GHz	Field strengths outside the shielded location from fixed RF transmitters, as determined by an electromagnetic site survey, should be less than 3V/m. Interference may occur in the vicinity of equipment marked with the following symbol: 

NOTE 1) These guidelines may not apply in all situations. Electromagnetic propagation is affected by absorption and reflection from structures, objects and people.

NOTE 2) It is essential that the actual shielding effectiveness and filter attenuation of the shielded location be verified to assure that they meet the minimum specification.

^a Field strengths from fixed transmitters, such as base stations for radio (cellular/cordless) telephones and land mobile radios, amateur radio, AM and FM radio broadcast and TV broadcast cannot be predicted theoretically with accuracy. To assess the electromagnetic environment due to fixed RF transmitters, an

electromagnetic site survey should be considered. If the measured field strength outside the shielded location in which the EUT is used exceeds 3V/m, the EUT should be observed to verify normal operation.

If abnormal performance is observed, additional measures may be necessary, such as relocating the EUT or using a shielded location with a higher RF shielding effectiveness and filter attenuation.

12. Electric Diagram

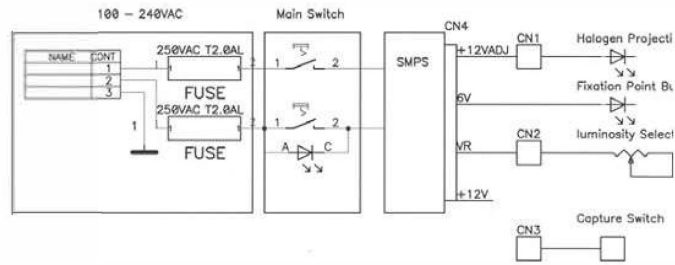

13. Technical Specifications

MICROSCOPE - HS-5000 3X	
Type	Galileian converging binocular
Magnification	3 positions rotation drum
Eyepiece	12.5x
Total magnification	10x, 16x, 25x
Real field of view	38.5, 22.2, 15.2, 10.5, 6.7 mm
Interpupillary adjust	55-80 mm
SLIT ILLUMINATION	
Slit length	0.3-12 mm(continuous)
Slit width	0-12 mm(continuous)
Slit projection	1x
Aperture diaphragms	0.3/1/3/5/9/12 mm
Filters	cobalt blue, red-free, gray and heat-absorption
Slit rotation	0°~180° continuous
Angle of incidence	0°, 5°, 10°, 15°, 20°
Patient's eye/mirror surface working distance	80 mm

BASE	
Vertical Movement	Min. 28mm
Longitudinal Movement	Min. 78mm.
Lateral Movement	Min. 98mm
Fine base Movement	Min. 10mm
Power supply	100~240 V AC 50/60HZ 2.0A
Power consumption	70VA
Instrument Voltage	12V DC
Halogen Projection bulb	12V 30W
Fixation point bulb	6V 0.2A

14. Service Information

How to contact service: If there are any problems with the equipment, please follow the steps below:

- First of all, refer to the 10. Maintenance and 11. Troubleshooting sections according to the problem that you are encountered. And then follow the suggested sequences.
- If the problem persists, please contact the local distributor in your province or country at first.
- Before calling to the local distributor, you'd better check these information such as Model and Serial Numbers. To do so, fill up the following table as soon as you purchase our product. You can look up these information at any time. The serial number is found on the back of this unit. The serial number is unique to this unit. You should retain this manual as a permanent record of your purchase. Please retain your purchase receipt as your proof of purchase.

Date of Purchase: _____

Dealer's Name: _____

Dealer Address: _____

Dealer Phone No.: _____

Model No.: _____

Serial No.: _____

- If you can't contact with your local distributor, you can directly get in touch with the service department of the HUVITZ using the phone number and the address written in the below table.

How to Contact HUVITZ Co., Ltd

